

# DIESEL GENERATOR SET

## MTU 6R1600 DS300

300 kVA / 50 Hz / Standby (Fuel-Optimized)  
380 - 415V

Reference MTU 6R1600 DS300 (275 kVA Fuel and Exhaust-Optimized) for Prime Rating Technical Data



### SYSTEM RATINGS

#### Standby

Voltage (L-L)	380V	400V	415V
Phase	3	3	3
PF	0.8	0.8	0.8
Hz	50	50	50
kW	240	240	240
kVA	300	300	300
Amps	456	433	417
skVA@30%			
Voltage Dip	440	650	540
Generator Model	432CSL6212	433CSL6216	432CSL6212
Temp Rise	150 °C/40 °C	150 °C/40 °C	150 °C/40 °C
Connection	12 LEAD WYE	12 LEAD WYE	12 LEAD WYE

### CERTIFICATIONS AND STANDARDS

// **Generator set is designed and manufactured in facilities certified to standards ISO 9001:2008 and ISO 14001:2004**

// **Seismic Certification – Optional**

- IBC Certification
- OSHPD Pre-Approval

// **Performance Assurance Certification (PAC)**

- Generator Set Tested to ISO 8528-5 for Transient Response
- Verified product design, quality and performance integrity
- All engine systems are prototype and factory tested

// **Power Rating**

- Accepts Rated Load in One Step Per NFPA 110
- Permissible average power output during 24 hours of operation is approved up to 85%.

## STANDARD FEATURES\*

- // MTU Onsite Energy is a single source supplier
- // Global Product Support
- // 2 Year Standard Warranty
- // 6R1600 Diesel Engine
  - 10.5 Liter Displacement
  - Common Rail Fuel Injection
  - 4-Cycle
- // Engine-generator resilient mounted
- // Complete Range of Accessories
- // Generator
  - Brushless, Rotating Field Generator
  - 2/3 Pitch Windings
  - 300% Short Circuit Capability with Optional Permanent Magnet Generator (PMG)
- // Digital Control Panel(s)
  - UL Recognized, CSA Certified, NFPA 110
  - Complete System Metering
  - LCD Display
- // Cooling System
  - Integral Set-Mounted
  - Engine-Driven Fan

## STANDARD EQUIPMENT\*

### // Engine

Air Cleaner  
 Oil Pump  
 Oil Drain Extension and S/O Valve  
 Full Flow Oil Filters  
 Closed Crankcase Ventilation  
 Jacket Water Pump  
 Thermostats  
 Blower Fan and Fan Drive  
 Radiator - Unit Mounted  
 Electric Starting Motor - 24V  
 Governor - Electronic Isochronous  
 Base - Formed Steel  
 SAE Flywheel and Bell Housing  
 Charging Alternator - 24V  
 Battery Box and Cables  
 Flexible Fuel Connectors  
 Flexible Exhaust Connection

### // Generator

NEMA MG1, IEEE and ANSI standards compliance for temperature rise and motor starting  
 Sustained short circuit current of up to 300% of the rated current for up to 10 seconds  
 Self-Ventilated and Drip-Proof  
 Superior Voltage Waveform  
 Digital, Solid State, Volts-per-Hertz Regulator  
 No Load to Full Load Regulation

Brushless Alternator with Brushless Pilot Exciter  
 4 Pole, Rotating Field  
 150 °C Max. Standby Temperature Rise  
 1 Bearing, Sealed  
 Flexible Coupling  
 Full Amortisseur Windings  
 125% Rotor Balancing  
 3-Phase Voltage Sensing  
 ±1% Voltage Regulation  
 100% of Rated Load - One Step  
 5% Max. Total Harmonic Distortion

### // Digital Control Panel(s)

Digital Metering  
 Engine Parameters  
 Generator Protection Functions  
 Engine Protection  
 CANBus ECU Communications  
 Windows®-Based Software  
 Multilingual Capability  
 Remote Communications to RDP-110 Remote Annunciator  
 Programmable Input and Output Contacts  
 UL Recognized, CSA Certified, CE Approved  
 Event Recording  
 IP 54 Front Panel Rating with Integrated Gasket  
 NFPA110 Compatible

\* Represents standard product only. Consult Factory/MTU Onsite Energy Distributor for additional configurations.

## APPLICATION DATA

### // Engine

Manufacturer	MTU
Model	6R1600G70F
Type	4-Cycle
Arrangement	6-Inline
Displacement: L (Cu In)	10.5 (641)
Bore: cm (in)	12.2 (4.8)
Stroke: cm (in)	15 (5.91)
Compression Ratio	17.5:1
Rated RPM	1,500
Engine Governor	ECU 8
Max. Power: kWm (bhp)	274 (367)
Speed Regulation	±0.25%
Air Cleaner	Dry

### // Liquid Capacity (Lubrication)

Total Oil System: L (gal)	46 (12.2)
Engine Jacket Water Capacity: L (gal)	45 (11.9)
System Coolant Capacity: L (gal)	82 (21.7)

### // Electrical

Electric Volts DC	24
Cold Cranking Amps Under -17.8 °C (0 °F)	950

### // Fuel System

Fuel Supply Connection Size	-10 JIC 37° Female M20 x 1.5 Male Adapter Provided
Fuel Return Connection Size	-6 JIC 37° Female M14 x 1.5 Male Adapter Provided
Max. Fuel Lift: m (ft)	5 (16)
Recommended Fuel	Diesel #2
Total Fuel Flow: L/hr (gal/hr)	171 (52.1)

### // Fuel Consumption

At 100% of Power Rating: L/hr (gal/hr)	64 (16.8)
At 75% of Power Rating: L/hr (gal/hr)	47 (12.4)
At 50% of Power Rating: L/hr (gal/hr)	33 (8.6)

### // Cooling - Radiator System

Ambient Capacity of Radiator: °C (°F)	50 (122)
Max. Restriction of Cooling Air: Intake and Discharge Side of Rad.: kPa (in. H <sub>2</sub> O)	0.2 (0.8)
Water Pump Capacity: L/min (gpm)	277 (73.1)
Heat Rejection to Coolant: kW (BTUM)	144 (8,189)
Heat Rejection to After Cooler: kW (BTUM)	60 (3,412)
Heat Radiated to Ambient: kW (BTUM)	28 (1,592)
Fan Power: kW (hp)	10.8 (14.5)

### // Air Requirements

Aspirating: *m <sup>3</sup> /min (SCFM)	24 (847.6)
Air Flow Required for Rad. Cooled Unit: *m <sup>3</sup> /min (SCFM)	372 (13,137)
Remote Cooled Applications; Air Flow Required for Dissipation of Radiated Generator Set Heat for a Max. of 25 °F Rise: *m <sup>3</sup> /min (SCFM)	101.7 (3,591)

\* Air density = 1.184 kg/m<sup>3</sup> (0.0739 lbm/ft<sup>3</sup>)

### // Exhaust System

Gas Temp. (Stack): °C (°F)	485 (905)
Gas Volume at Stack Temp: m <sup>3</sup> /min (CFM)	60 (2,118.9)
Max. Allowable Back Pressure: kPa (in. H <sub>2</sub> O)	15 (60.2)

## WEIGHTS AND DIMENSIONS

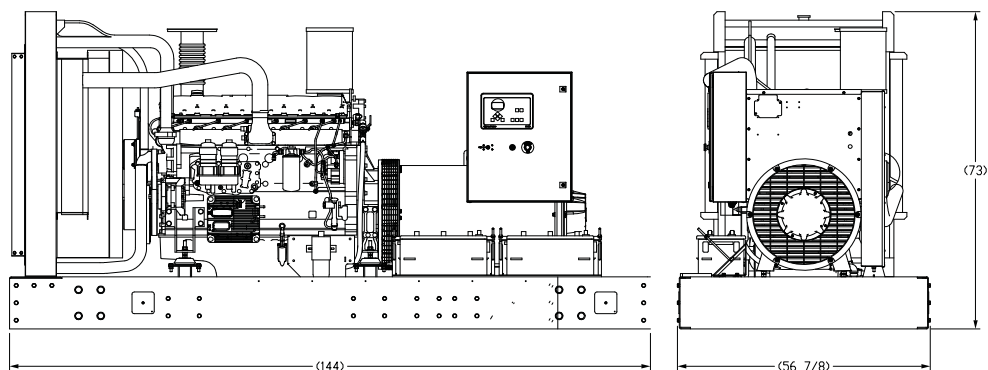

Drawing above for illustration purposes only, based on standard open power 400 volt generator set. Lengths may vary with other voltages. Do not use for installation design. See website for unit specific template drawings.

System	Dimensions (LxWxH)	Weight (dry/less tank)
Open Power Unit (OPU)	3,658 x 1,445 x 1,855 mm (144 x 56.875 x 73 in)	3,078 kg (6,785 lb)

Weights and dimensions are based on open power units and are estimates only. Consult the factory for accurate weights and dimensions for your specific generator set.

## SOUND DATA

Unit Type	Standby Full Load
Level 0: Open Power Unit dB(A)	85

Sound data is provided at 7 m (23 ft). Generator set tested in accordance with ISO 8528-10 and with infinite exhaust.

## EMISSIONS DATA

NO <sub>x</sub> + NMHC	CO	PM
C/F	C/F	C/F

## RATING DEFINITIONS AND CONDITIONS

- // Standby ratings apply to installations served by a reliable utility source. The standby rating is applicable to varying loads for the duration of a power outage. No overload capability for this rating. Ratings are in accordance with ISO 8528-1, ISO 3046-1, BS 5514, and AS 2789. Average load factor: ≤ 85%. Operating hours per year: Max. 500.
- // Deration Factor:
  - Altitude:** Consult your local MTU Onsite Energy Power Generation Distributor for altitude derations.
  - Temperature:** Consult your local MTU Onsite Energy Power Generation Distributor for temperature derations.

C/F = Consult Factory/MTU Onsite Energy Distributor

N/A = Not Available