



## Diesel Generator Set

# mtu 12V4000 DS2000

380V – 11 kV/50 Hz/prime power/fuel consumption optimized  
12V4000G24F/water charge air cooling



Optional equipment and finishing shown. Standard may vary.

## Product highlights

### Benefits

- Low fuel consumption
- Optimized system integration ability
- High reliability
- High availability of power
- Long maintenance intervals

### Support

- Global product support offered

### Standards

- Engine-generator set is designed and manufactured in facilities certified to standards ISO 2008:9001 and ISO 2004:14001
- Generator set complies to ISO 8528
- Generator meets NEMA MG1, BS5000, ISO, DIN EN and IEC standards
- NFPA 110

### Power rating

- System ratings: 1870 kVA - 1880 kVA
- Accepts rated load in one step per NFPA 110
- Generator set complies to G3 according to ISO 8528-5
- Generator set exceeds load steps according to ISO 8528-5

### Performance assurance certification (PAC)

- Engine-generator set tested to ISO 8528-5 for transient response
- 75% load factor
- Verified product design, quality and performance integrity
- All engine systems are prototype and factory tested

### Complete range of accessories available

- Control panel
- Power panel
- Circuit breaker/power distribution
- Fuel system
- Fuel connections with shut-off valve mounted to base frame
- Starting/charging system
- Exhaust system
- Mechanical and electrical driven radiators
- Medium and oversized voltage alternators

### Emissions

- Fuel consumption optimized

### Certifications

- CE certification option
- Unit certificate acc. to BDEW (German Grid-Code)



A Rolls-Royce  
solution

## Application data <sup>1)</sup>

<b>Engine</b>		<b>Liquid capacity (lubrication)</b>	
Manufacturer	<b>mtu</b>	Total oil system capacity: l	260
Model	12V4000G24F	Engine jacket water capacity: l	160
Type	4-cycle	Intercooler coolant capacity: l	40
Arrangement	12V	<b>Combustion air requirements</b>	
Displacement: l	57.2	Combustion air volume: m <sup>3</sup> /s	1.8
Bore: mm	170	Max. air intake restriction: mbar	50
Stroke: mm	210	<b>Cooling/radiator system</b>	
Compression ratio	16.4	Coolant flow rate (HT circuit): m <sup>3</sup> /hr	56
Rated speed: rpm	1500	Coolant flow rate (LT circuit): m <sup>3</sup> /hr	30
Engine governor	ECU 9	Heat rejection to coolant: kW	580
Max power: kWm	1575	Heat radiated to charge air cooling: kW	260
Air cleaner	dry	Heat radiated to ambient: kW	75
<b>Fuel system</b>		Fan power for electr. radiator (40°C): kW	38
Maximum fuel lift: m	5	<b>Exhaust system</b>	
Total fuel flow: l/min	16	Exhaust gas temp. (after turbocharger): °C	440
<b>Fuel consumption <sup>2)</sup></b>		Exhaust gas volume: m <sup>3</sup> /s	4.5
At 100% of power rating:	364.3	Maximum allowable back pressure: mbar	85
At 75% of power rating:	274.7	Minimum allowable back pressure: mbar	30
At 50% of power rating:	189.8		

## Standard and optional features

### System ratings (kW/kVA)

Generator model	Voltage	fuel consumption optimized					
		without radiator			with mechanical radiator		
		kWel	kVA*	AMPS	kWel	kVA*	AMPS
Leroy Somer LSA52.3 S6 (Low voltage Leroy Somer standard)	380 V	1504	1880	2856	1472	1840	2796
	400 V	1504	1880	2714	1472	1840	2656
	415 V	1504	1880	2615	1472	1840	2560
Leroy Somer LSA52.3 S7 (Low voltage Leroy Somer oversized)	380 V	1504	1880	2856	1472	1840	2796
	400 V	1504	1880	2714	1472	1840	2656
	415 V	1504	1880	2615	1472	1840	2560
Marathon 743RSL7091 (Low voltage Marathon)	380 V	1496	1870	2841	1456	1820	2765
	400 V	1504	1880	2714	1456	1820	2627
	415 V	1496	1870	2602	1456	1820	2532
Marathon 744RSL7092 (Low voltage Marathon oversized)	380 V	1496	1870	2841	1456	1820	2765
	400 V	1504	1880	2714	1456	1820	2627
	415 V	1496	1870	2602	1456	1820	2532
Marathon 1020FDH7096 (Medium volt. marathon)	11kV	1496	1870	98	1456	1820	96
Leroy Somer LSA53.2 VL7 (Medium volt. Leroy Somer)	11 kV	1504	1880	99	1472	1840	97

\* cos phi = 0.8

1 All data refers only to the engine and is based on ISO standard conditions (25°C and 100m above sea level).

2 Values referenced are in accordance with ISO 3046-1. Conversion calculated with fuel density of 0.83 g/ml. All fuel consumption values refer to rated engine power.

## Standard and optional features

### Engine

- 4-cycle
- Standard single stage air filter
- Oil drain extension & shut-off valve
- Closed crankcase ventilation
- Governor-electronic isochronous
- Common rail fuel injection
- Fuel consumption optimized engine

### Generator

- 4 pole three-phase synchronous generator
- Brushless, self-excited, self-regulating, self-ventilated
- Digital voltage regulator
- Anti condensation heater
- Stator winding Y-connected, accessible neutral (brought out)
- Protection IP23
- Insulation class H, utilization acc. to H
- Radio suppression EN55011, group 1, cl. B
- Short circuit capability 3xIn for 10sec
- Winding and bearing RTDs (without monitoring)
- Excitation by AREP
- Mounting of CT's: 2 core CT's
- Winding pitch: 2/3 winding
- Voltage setpoint adjustment  $\pm 10\%$
- Meets NEMA MG-1, BS 5000, IEC 60034-1, VDE 0530, DIN EN 12601, AS1359 and ISO 8528 requirements
- Leroy Somer low voltage generator
- Marathon low voltage generator
- Oversized generator
- Medium voltage generator

### Cooling system

- Jacket water pump
- Thermostat(s)
- Water charge air cooling
- Mechanical radiator
- Electrical driven front-end cooler
- Jacket water heater

### Control panel

- Pre-wired control cabinet for easy application of customized controller (V1+)
- Island operation (V2)
- Automatic mains failure operation with ATS (V3a)
- Automatic mains failure operation incl. control of generator and mains breaker (V3b)
- Island parallel operation of multiple gensets (V4)
- Automatic mains failure operation with short (< 10s) mains parallel overlap synchronization (V5)
- Mains parallel operation of a single genset (V6)
- Mains parallel operation of multiple gensets (V7)
- Basler controller
- Deif controller
- Complete system metering
- Digital metering
- Engine parameters
- Generator protection functions
- Engine protection
- SAE J1939 engine ECU communications
- Parametrization software
- Multilingual capability
- Multiple programmable contact inputs
- Multiple contact outputs
- Event recording
- IP 54 front panel rating with integrated gasket
- Different expansion modules
- Remote annunciator
- Daytank control
- Generator winding temperature monitoring
- Generator bearing temperature monitoring
- Modbus TCP-IP

### Power panel

- Available in 600x600 and 600x1000
- Phase monitoring relay 230V/400V
- Supply for battery charger
- Supply for jacket water heater
- Supply for anti condensation heating
- Plug socket cabinet for 230V compatible Euro/USA
- Supply for electrical driven radiator from 45kW – 75kW (PP 600x1000)

- Represents standard features
- Represents optional features

## Standard and optional features

### Circuit breaker/power distribution

- 3-pole circuit breaker
- 4-pole circuit breaker
- Manual-actuated circuit breaker
- Electrical-actuated circuit breaker
- Stand-alone solution in separate cabinet

### Fuel system

- Flexible fuel connectors mounted to base frame
- Fuel filter with water separator
- Fuel filter with water separator heavy-duty
- Switchable fuel filter with water separator
- Switchable fuel filter with water separator heavy-duty
- Separate fuel cooler
- Fuel cooler integrated into cooling equipment

### Starting/charging system

- 24V starter
- Starter batteries, cables, rack, disconnect switch
- Battery charger

### Mounting system

- Welded base frame
- Resilient engine and generator mounting
- Modular base frame design

### Exhaust system

- Exhaust bellows with connection flange
- Exhaust silencer with 10 dB(A) sound attenuation
- Exhaust silencer with 30 dB(A) sound attenuation
- Exhaust silencer with 40 dB(A) sound attenuation
- Y-connection-pipe

Represents standard features

Represents optional features

## Weights and dimensions

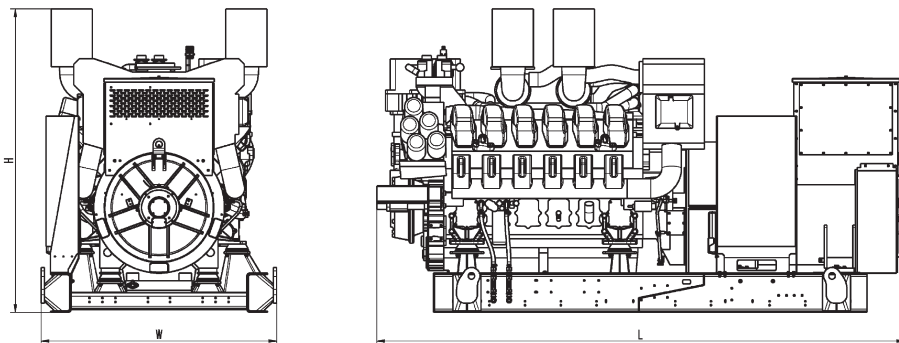

Drawing above for illustration purposes only, based on a standard open power 400 Volt engine-generator set. Lengths may vary with other voltages. Do not use for installation design. See website for unit specific template drawings.

System	Dimensions (LxWxH)	Weight (dry/less tank)
Open power unit (OPU)	4059 x 1810 x 2330 mm	10949 kg

Weights and dimensions are based on open power units and are estimates only. Consult the factory for accurate weights and dimensions for your specific engine-generator set.

## Sound data

– Consult your local **mtu** distributor for sound data.

## Emissions data

– Consult your local **mtu** distributor for emissions data.

## Rating definitions and conditions

- Prime power ratings apply to installations where utility power is unavailable or unreliable. At varying load, the number of generator set operating hours is unlimited. A 10% overload capacity is available for one hour in twelve. Ratings are in accordance with ISO 8528-1, ISO 3046-1, BS 5514 and AS 2789. Average load factor:  $\leq 75\%$ .
- Consult your local **mtu** distributor for derating information.