

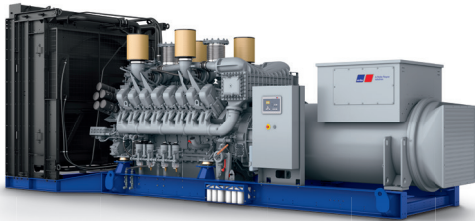

## Diesel Generator Set

# mtu 16V4000 DS2250

380V – 11 kV/50 Hz/prime power for stationary emergency/  
fuel consumption optimized/16V4000G14F/water charge air cooling



Optional equipment and finishing shown. Standard may vary.

## Product highlights

### Benefits

- Low fuel consumption
- Optimized system integration ability
- High reliability
- High availability of power
- Long maintenance intervals

### Support

- Global product support offered

### Standards

- Engine-generator set is designed and manufactured in facilities certified to standards ISO 2008:9001 and ISO 2004:14001
- Generator set complies to ISO 8528
- Generator meets NEMA MG1, BS5000, ISO, DIN EN and IEC standards
- NFPA 110

### Power rating

- System ratings: 2090 kVA - 2160 kVA
- Accepts rated load in one step per NFPA 110
- Generator set complies to G3 according to ISO 8528-5
- Generator set exceeds load steps according to ISO 8528-5

### Performance assurance certification (PAC)

- Engine-generator set tested to ISO 8528-5 for transient response
- 85% load factor
- Verified product design, quality and performance integrity
- All engine systems are prototype and factory tested

### Complete range of accessories available

- Control panel
- Power panel
- Circuit breaker/power distribution
- Fuel system
- Fuel connections with shut-off valve mounted to base frame
- Starting/charging system
- Exhaust system
- Mechanical and electrical driven radiators
- Medium and oversized voltage alternators

### Emissions

- Fuel consumption optimized

### Certifications

- CE certification option
- Unit certificate acc. to BDEW (German Grid-Code)



A Rolls-Royce  
solution

## Application data <sup>1)</sup>

### Engine

Manufacturer	<b>mtu</b>
Model	16V4000G14F
Type	4-cycle
Arrangement	16V
Displacement: l	76.3
Bore: mm	170
Stroke: mm	210
Compression ratio	16.4
Rated speed: rpm	1500
Engine governor	ECU 9
Max power: kWm	1798
Air cleaner	dry

### Fuel system

Maximum fuel lift: m	5
Total fuel flow: l/min	20

### Fuel consumption <sup>2)</sup>

	l/hr	g/kwh
At 100% of power rating:	407.3	188
At 75% of power rating:	310.3	191
At 50% of power rating:	217.7	201

### Liquid capacity (lubrication)

Total oil system capacity: l	300
Engine jacket water capacity: l	175
Intercooler coolant capacity: l	50

### Combustion air requirements

Combustion air volume: m <sup>3</sup> /s	2.1
Max. air intake restriction: mbar	50

### Cooling/radiator system

Coolant flow rate (HT circuit): m <sup>3</sup> /hr	68.5
Coolant flow rate (LT circuit): m <sup>3</sup> /hr	30
Heat rejection to coolant: kW	710
Heat radiated to charge air cooling: kW	260
Heat radiated to ambient: kW	90
Fan power for electr. radiator (40°C): kW	38

### Exhaust system

Exhaust gas temp. (after turbocharger): °C	480
Exhaust gas volume: m <sup>3</sup> /s	5.4
Maximum allowable back pressure: mbar	85
Minimum allowable back pressure: mbar	30

## Standard and optional features

### System ratings (kW/kVA)

Generator model	Voltage	fuel consumption optimized					
		without radiator			with mechanical radiator		
		kWel	kVA*	AMPS	kWel	kVA*	AMPS
Leroy Somer LSA52.3 S7 (Low voltage Leroy Somer standard)	380 V	1728	2160	3282	1688	2110	3206
	400 V	1728	2160	3118	1688	2110	3046
	415 V	1728	2160	3005	1688	2110	2935
Marathon 744RSL7092 (Low voltage Marathon)	380 V	1704	2130	3236	1672	2090	3175
	400 V	1704	2130	3074	1672	2090	3017
	415 V	1696	2120	2949	1672	2090	2908
Marathon 744RSL7093 (Low voltage Marathon oversized)	380 V	1704	2130	3236	1672	2090	3175
	400 V	1704	2130	3074	1672	2090	3017
	415 V	1696	2120	2949	1672	2090	2908
Marathon 1020FDH7097 (Medium volt. marathon)	11 kV	1712	2140	112	1672	2090	110
Leroy Somer LSA53.2 XL9 (Medium volt. Leroy Somer)	11 kV	1728	2160	113	1688	2110	111

\* cos phi = 0.8

1 All data refers only to the engine and is based on ISO standard conditions (25°C and 100m above sea level).

2 Values referenced are in accordance with ISO 3046-1. Conversion calculated with fuel density of 0.83 g/ml. All fuel consumption values refer to rated engine power.

## Standard and optional features

### Engine

- 4-cycle
- Standard single stage air filter
- Oil drain extension & shut-off valve
- Closed crankcase ventilation
- Governor-electronic isochronous
- Common rail fuel injection
- Fuel consumption optimized engine

### Generator

- 4 pole three-phase synchronous generator
- Brushless, self-excited, self-regulating, self-ventilated
- Digital voltage regulator
- Anti condensation heater
- Stator winding Y-connected, accessible neutral (brought out)
- Protection IP23
- Insulation class H, utilization acc. to H
- Radio suppression EN55011, group 1, cl. B
- Short circuit capability 3xIn for 10sec
- Winding and bearing RTDs (without monitoring)
- Excitation by AREP
- Mounting of CT's: 2 core CT's
- Winding pitch: 2/3 winding
- Voltage setpoint adjustment  $\pm 10\%$
- Meets NEMA MG-1, BS 5000, IEC 60034-1, VDE 0530, DIN EN 12601, AS1359 and ISO 8528 requirements
- Leroy Somer low voltage generator
- Marathon low voltage generator
- Oversized generator
- Medium voltage generator

### Cooling system

- Jacket water pump
- Thermostat(s)
- Water charge air cooling
- Mechanical radiator
- Electrical driven front-end cooler
- Jacket water heater

### Control panel

- Pre-wired control cabinet for easy application of customized controller (V1+)
- Island operation (V2)
- Automatic mains failure operation with ATS (V3a)
- Automatic mains failure operation incl. control of generator and mains breaker (V3b)
- Island parallel operation of multiple gensets (V4)
- Automatic mains failure operation with short (< 10s) mains parallel overlap synchronization (V5)
- Mains parallel operation of a single genset (V6)
- Mains parallel operation of multiple gensets (V7)
- Basler controller
- Deif controller
- Complete system metering
- Digital metering
- Engine parameters
- Generator protection functions
- Engine protection
- SAE J1939 engine ECU communications
- Parametrization software
- Multilingual capability
- Multiple programmable contact inputs
- Multiple contact outputs
- Event recording
- IP 54 front panel rating with integrated gasket
- Different expansion modules
- Remote annunciator
- Daytank control
- Generator winding temperature monitoring
- Generator bearing temperature monitoring
- Modbus TCP-IP

### Power panel

- Available in 600x600 and 600x1000
- Phase monitoring relay 230V/400V
- Supply for battery charger
- Supply for jacket water heater
- Supply for anti condensation heating
- Plug socket cabinet for 230V compatible Euro/USA
- Supply for electrical driven radiator from 45kW – 75kW (PP 600x1000)

- Represents standard features
- Represents optional features

## Standard and optional features

### Circuit breaker/power distribution

- 3-pole circuit breaker
- 4-pole circuit breaker
- Manual-actuated circuit breaker
- Electrical-actuated circuit breaker
- Stand-alone solution in separate cabinet

### Fuel system

- Flexible fuel connectors mounted to base frame
- Fuel filter with water separator
- Fuel filter with water separator heavy-duty
- Switchable fuel filter with water separator
- Switchable fuel filter with water separator heavy-duty
- Separate fuel cooler
- Fuel cooler integrated into cooling equipment

### Starting/charging system

- 24V starter
- Starter batteries, cables, rack, disconnect switch
- Battery charger

### Mounting system

- Welded base frame
- Resilient engine and generator mounting
- Modular base frame design

### Exhaust system

- Exhaust bellows with connection flange
- Exhaust silencer with 10 dB(A) sound attenuation
- Exhaust silencer with 30 dB(A) sound attenuation
- Exhaust silencer with 40 dB(A) sound attenuation
- Y-connection-pipe

Represents standard features

Represents optional features

## Weights and dimensions

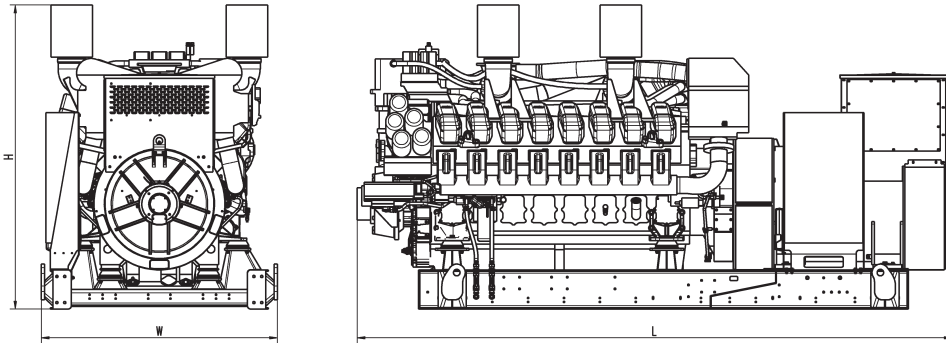

Drawing above for illustration purposes only, based on a standard open power 400 Volt engine-generator set. Lengths may vary with other voltages. Do not use for installation design. See website for unit specific template drawings.

System	Dimensions (LxWxH)	Weight (dry/less tank)
Open power unit (OPU)	4766 x 1810 x 2330 mm	12428 kg

Weights and dimensions are based on open power units and are estimates only. Consult the factory for accurate weights and dimensions for your specific engine-generator set.

## Sound data

– Consult your local **mtu** distributor for sound data.

## Emissions data

– Consult your local **mtu** distributor for emissions data.

## Rating definitions and conditions

- Standby ratings apply to installations served by a reliable utility source. The standby rating is applicable to varying loads for the duration of a power outage. A 10% overload capacity is available for one hour in twelve. Ratings are in accordance with ISO 8528-1, ISO-3046-1, BS 5514 and AS 2789.  
Average load factor:  $\leq 85\%$ . Operating hours/year: max. 500.
- Consult your local **mtu** distributor for derating information.