

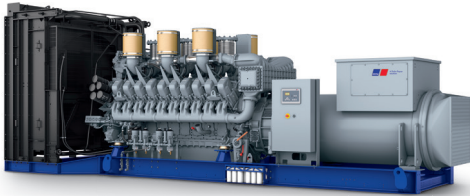

## Diesel Generator Set

# mtu 20V4000 DS3100

380V – 11 kV/50 Hz/grid stability power/  
fuel consumption optimized/20V4000G24F/water charge air cooling



Optional equipment and finishing shown. Standard may vary.

## Product highlights

### Benefits

- Low fuel consumption
- Optimized system integration ability
- High reliability
- High availability of power
- Long maintenance intervals

### Support

- Global product support offered

### Standards

- Engine-generator set is designed and manufactured in facilities certified to standards ISO 2008:9001 and ISO 2004:14001
- Generator set complies to ISO 8528
- Generator meets NEMA MG1, BS5000, ISO, DIN EN and IEC standards
- NFPA 110

### Power rating

- System ratings: 2820 kVA - 2910 kVA
- Accepts rated load in one step per NFPA 110
- Generator set complies to G3 according to ISO 8528-5
- Generator set exceeds load steps according to ISO 8528-5

### Performance assurance certification (PAC)

- Engine-generator set tested to ISO 8528-5 for transient response
- 100% load factor
- Verified product design, quality and performance integrity
- All engine systems are prototype and factory tested

### Complete range of accessories available

- Control panel
- Power panel
- Circuit breaker/power distribution
- Fuel system
- Fuel connections with shut-off valve mounted to base frame
- Starting/charging system
- Exhaust system
- Mechanical and electrical driven radiators
- Medium and oversized voltage alternators

### Emissions

- Fuel consumption optimized

### Certifications

- CE certification option
- Unit certificate acc. to BDEW (German Grid-Code)



A Rolls-Royce  
solution

## Application data <sup>1)</sup>

### Engine

Manufacturer	<b>mtu</b>
Model	20V4000G24F
Type	4-cycle
Arrangement	20V
Displacement: l	95.4
Bore: mm	170
Stroke: mm	210
Compression ratio	16.4
Rated speed: rpm	1500
Engine governor	ECU 9
Max power: kWm	2420
Air cleaner	dry

### Fuel system

Maximum fuel lift: m	5
Total fuel flow: l/min	27

### Fuel consumption <sup>2)</sup>

	l/hr	g/kwh
At 100% of power rating:	554	190
At 75% of power rating:	422	193
At 50% of power rating:	294.5	202

### Liquid capacity (lubrication)

Total oil system capacity: l	390
Engine jacket water capacity: l	205
Intercooler coolant capacity: l	50

### Combustion air requirements

Combustion air volume: m <sup>3</sup> /s	2.7
Max. air intake restriction: mbar	50

### Cooling/radiator system

Coolant flow rate (HT circuit): m <sup>3</sup> /hr	80
Coolant flow rate (LT circuit): m <sup>3</sup> /hr	32.5
Heat rejection to coolant: kW	890
Heat radiated to charge air cooling: kW	350
Heat radiated to ambient: kW	105
Fan power for electr. radiator (40°C): kW	70

### Exhaust system

Exhaust gas temp. (after turbocharger): °C	560
Exhaust gas volume: m <sup>3</sup> /s	7.1
Maximum allowable back pressure: mbar	85
Minimum allowable back pressure: mbar	30

## Standard and optional features

### System ratings (kW/kVA)

Generator model	Voltage	Fuel consumption optimized					
		without radiator			with mechanical radiator		
		kWel	kVA*	AMPS	kWel	kVA*	AMPS
Leroy Somer LSA53.2 M12 (Low voltage Leroy Somer standard)	380 V	2328	2910	4421	2264	2830	4300
	400 V	2328	2910	4200	2264	2830	4085
	415 V	2328	2910	4048	2264	2830	3937
Marathon 1030FDL7094 (Low voltage Marathon)	380 V	2328	2910	4421	2256	2820	4285
	400 V	2320	2900	4186	2256	2820	4070
	415 V	2320	2900	4034	2256	2820	3923
Marathon 1030FDH7101 (Medium volt. marathon)	11 kV	2320	2900	152	2256	2820	148
Leroy Somer LSA53.2 ZL14 (Medium volt. Leroy Somer)	11 kV	2328	2910	153	2264	2830	149

\* cos phi = 0.8

1 All data refers only to the engine and is based on ISO standard conditions (25°C and 100m above sea level).

2 Values referenced are in accordance with ISO 3046-1. Conversion calculated with fuel density of 0.83 g/ml. All fuel consumption values refer to rated engine power.

## Standard and optional features

### Engine

- 4-cycle
- Standard single stage air filter
- Oil drain extension & shut-off valve
- Closed crankcase ventilation
- Governor-electronic isochronous
- Common rail fuel injection
- Fuel consumption optimized engine

### Generator

- 4 pole three-phase synchronous generator
- Brushless, self-excited, self-regulating, self-ventilated
- Digital voltage regulator
- Anti condensation heater
- Stator winding Y-connected, accessible neutral (brought out)
- Protection IP23
- Insulation class H, utilization acc. to H
- Radio suppression EN55011, group 1, cl. B
- Short circuit capability 3xIn for 10sec
- Winding and bearing RTDs (without monitoring)
- Excitation by AREP
- Mounting of CT's: 2 core CT's
- Winding pitch: 2/3 winding
- Voltage setpoint adjustment  $\pm 10\%$
- Meets NEMA MG-1, BS 5000, IEC 60034-1, VDE 0530, DIN EN 12601, AS1359 and ISO 8528 requirements
- Leroy Somer low voltage generator
- Marathon low voltage generator
- Oversized generator
- Medium voltage generator

### Cooling system

- Jacket water pump
- Thermostat(s)
- Water charge air cooling
- Mechanical radiator
- Electrical driven front-end cooler
- Jacket water heater

### Control panel

- Pre-wired control cabinet for easy application of customized controller (V1+)
- Island operation (V2)
- Automatic mains failure operation with ATS (V3a)
- Automatic mains failure operation incl. control of generator and mains breaker (V3b)
- Island parallel operation of multiple gensets (V4)
- Automatic mains failure operation with short (< 10s) mains parallel overlap synchronization (V5)
- Mains parallel operation of a single genset (V6)
- Mains parallel operation of multiple gensets (V7)
- Basler controller
- Deif controller
- Complete system metering
- Digital metering
- Engine parameters
- Generator protection functions
- Engine protection
- SAE J1939 engine ECU communications
- Parametrization software
- Multilingual capability
- Multiple programmable contact inputs
- Multiple contact outputs
- Event recording
- IP 54 front panel rating with integrated gasket
- Different expansion modules
- Remote annunciator
- Daytank control
- Generator winding temperature monitoring
- Generator bearing temperature monitoring
- Modbus TCP-IP

### Power panel

- Available in 600x600 and 600x1000
- Phase monitoring relay 230V/400V
- Supply for battery charger
- Supply for jacket water heater
- Supply for anti condensation heating
- Plug socket cabinet for 230V compatible Euro/USA
- Supply for electrical driven radiator from 45kW – 75kW (PP 600x1000)

- Represents standard features
- Represents optional features

## Standard and optional features

### Circuit breaker/power distribution

- 3-pole circuit breaker
- 4-pole circuit breaker
- Manual-actuated circuit breaker
- Electrical-actuated circuit breaker
- Stand-alone solution in separate cabinet

### Fuel system

- Flexible fuel connectors mounted to base frame
- Fuel filter with water separator
- Fuel filter with water separator heavy-duty
- Switchable fuel filter with water separator
- Switchable fuel filter with water separator heavy-duty
- Separate fuel cooler
- Fuel cooler integrated into cooling equipment

### Starting/charging system

- 24V starter
- Starter batteries, cables, rack, disconnect switch
- Battery charger

### Mounting system

- Welded base frame
- Resilient engine and generator mounting
- Modular base frame design

### Exhaust system

- Exhaust bellows with connection flange
- Exhaust silencer with 10 dB(A) sound attenuation
- Exhaust silencer with 30 dB(A) sound attenuation
- Exhaust silencer with 40 dB(A) sound attenuation
- Y-connection-pipe

Represents standard features

Represents optional features

## Weights and dimensions

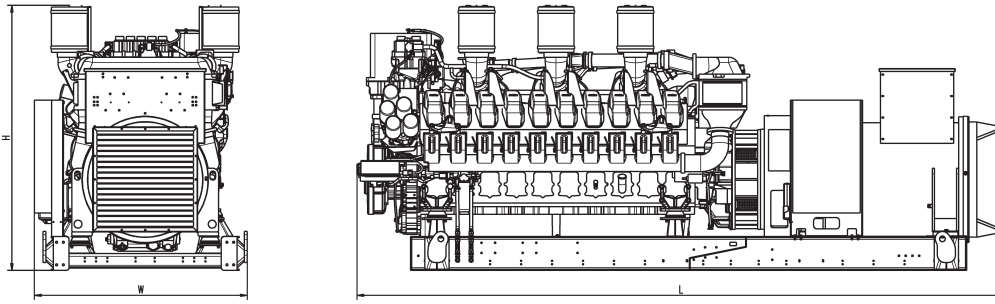

Drawing above for illustration purposes only, based on a standard open power 400 Volt engine-generator set. Lengths may vary with other voltages. Do not use for installation design. See website for unit specific template drawings.

System	Dimensions (LxWxH)	Weight (dry/less tank)
Open power unit (OPU)	5760 x 1887 x 2332 mm	15819 kg

Weights and dimensions are based on open power units and are estimates only. Consult the factory for accurate weights and dimensions for your specific engine-generator set.

## Sound data

– Consult your local **mtu** distributor for sound data.

## Emissions data

– Consult your local **mtu** distributor for emissions data.

## Rating definitions and conditions

- Grid stability power ratings apply to installations serving electric utility programs. At constant or varying load, the number of generator set operating hours is limited to 1000 hours per year with no more than 500 hours per year at 100% load without interruption. A 10% overload capacity is available for one hour in twelve. Ratings are in accordance with ISO 8528-1, ISO 3046-1, BS 5514 and AS 2789. Average load factor:  $\leq 100\%$ .
- Consult your local **mtu** distributor for derating information.