

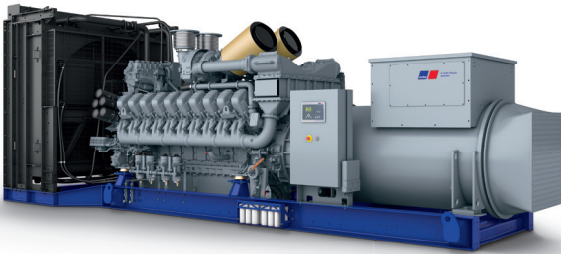

## Diesel Generator Set

# mtu 20V4000 DS4000

11 kV/50 Hz/prime power for stationary emergency/  
fuel consumption optimized/20V4000G44LF/water charge air cooling



Optional equipment and finishing shown. Standard may vary.

## Product highlights

### Benefits

- Low fuel consumption
- Optimized system integration ability
- High reliability
- High availability of power
- Long maintenance intervals

### Support

- Global product support offered

### Standards

- Engine-generator set is designed and manufactured in facilities certified to standards ISO 2008:9001 and ISO 2004:14001
- Generator set complies to ISO 8528
- Generator meets NEMA MG1, BS5000, ISO, DIN EN and IEC standards
- NFPA 110

### Power rating

- System rating: 3630 kVA
- Accepts rated load in one step per NFPA 110
- Generator set complies to G3 according to ISO 8528-5
- Generator set exceeds load steps according to ISO 8528-5

### Performance assurance certification (PAC)

- Engine-generator set tested to ISO 8528-5 for transient response
- 85% load factor
- Verified product design, quality and performance integrity
- All engine systems are prototype and factory tested

### Complete range of accessories available

- Control panel
- Power panel
- Fuel system
- Fuel connections with shut-off valve mounted to base frame
- Starting/charging system
- Exhaust system
- Electrical driven radiators
- Medium voltage alternators

### Emissions

- Fuel consumption optimized

### Certifications

- CE certification option



A Rolls-Royce  
solution

## Application data <sup>1)</sup>

### Engine

Manufacturer	<b>mtu</b>
Model	20V4000G44LF
Type	4-cycle
Arrangement	20V
Displacement: l	95.4
Bore: mm	170
Stroke: mm	210
Compression ratio	16.4
Rated speed: rpm	1500
Engine governor	ADEC (ECU 9)
Max power: kWm	3007
Air cleaner	dry

### Fuel system

Maximum fuel lift: m	5
Total fuel flow: l/min	27

### Fuel consumption <sup>2)</sup>

	l/hr	g/kwh
At 100% of power rating:	711	196
At 75% of power rating:	517	190
At 50% of power rating:	368	203

### Liquid capacity (lubrication)

Total oil system capacity: l	390
Engine jacket water capacity: l	260
Intercooler coolant capacity: l	50

### Combustion air requirements

Combustion air volume: m <sup>3</sup> /s	4.2
Max. air intake restriction: mbar	30

### Cooling/radiator system

Coolant flow rate (HT circuit): m <sup>3</sup> /hr	80
Coolant flow rate (LT circuit): m <sup>3</sup> /hr	50
Heat rejection to coolant: kW	1040
Heat radiated to charge air cooling: kW	775
Heat radiated to ambient: kW	105
Fan power for electr. radiator (40°C): kW	105

### Exhaust system

Exhaust gas temp. (after engine, max.): °C	445
Exhaust gas temp. (before turbocharger): °C	621
Exhaust gas volume: m <sup>3</sup> /s	10.3
Maximum allowable back pressure: mbar	50
Minimum allowable back pressure: mbar	-

## Standard and optional features

### System ratings (kW/kVA)

Generator model	Voltage	fuel consumption optimized 40°C/300m		
		without radiator		
		kWel	kVA*	AMPS
Leroy Somer LSA54.2 ZL12 (Med.volt. Leroy Somer)	11 kV	2904	3630	191
Marathon 1040FDH7105 (Medium volt. marathon)	11 kV	2904	3630	191
Leroy Somer LSA54.2 ZL14 (MV Leroy Somer oversized)	11 kV	2904	3630	191

\* cos phi = 0.8

1 All data refers only to the engine and is based on ISO standard conditions (25°C and 100m above sea level).

2 Values referenced are in accordance with ISO 3046-1. Conversion calculated with fuel density of 0.83 g/ml. All fuel consumption values refer to rated engine power.

## Standard and optional features

### Engine

- 4-cycle
- Standard single stage air filter
- Oil drain extension & shut-off valve
- Closed crankcase ventilation
- Governor-electronic isochronous
- Common rail fuel injection
- Fuel consumption optimized engine

### Generator

- 4 pole three-phase synchronous generator
- Brushless, self-excited, self-regulating, self-ventilated
- Digital voltage regulator
- Anti condensation heater
- Stator winding Y-connected, accessible neutral (brought out)
- Protection IP23
- Insulation class H, utilization acc. to H
- Radio suppression EN55011, group 1, cl. B
- Short circuit capability 3xIn for 10sec
- Winding and bearing RTDs (without monitoring)
- Excitation by AREP + PMI
- Mounting of CT's: 3x 2 core CT's
- Winding pitch: 5/6 winding
- Voltage setpoint adjustment  $\pm 5\%$
- Meets NEMA MG-1, BS 5000, IEC 60034-1, VDE 0530, DIN EN 12601, AS1359 and ISO 8528 requirements
- Leroy Somer medium voltage generator
- Marathon medium voltage generator
- Oversized generator

### Cooling system

- Jacket water pump
- Thermostat(s)
- Water charge air cooling
- Electrical driven front-end cooler
- Jacket water heater
- Pulley for fan drive

### Control panel

- Pre-wired control cabinet for easy application of customized controller (V1+)
- Island operation (V2)
- Automatic mains failure operation with ATS (V3a)
- Automatic mains failure operation incl. control of generator and mains breaker (V3b)
- Island parallel operation of multiple gensets (V4)
- Automatic mains failure operation with short (< 10s) mains parallel overlap synchronization (V5)
- Mains parallel operation of a single genset (V6)
- Mains parallel operation of multiple gensets (V7)
- Basler controller
- Deif controller
- Complete system metering
- Digital metering
- Engine parameters
- Generator protection functions
- Engine protection
- SAE J1939 engine ECU communications
- Parametrization software
- Multilingual capability
- Multiple programmable contact inputs
- Multiple contact outputs
- Event recording
- IP 54 front panel rating with integrated gasket
- Remote annunciator
- Daytank control
- Generator winding temperature and temperature monitoring
- Modbus TCP-IP

### Power panel

- Available in 600x600 mm
- Phase monitoring relay 230V/400V
- Supply for battery charger
- Supply for jacket water heater
- Supply for anti condensation heating
- Plug socket cabinet for 230V compatible Euro/USA

- Represents standard features
- Represents optional features

## Standard and optional features

### Fuel system

- Flexible fuel connectors mounted to base frame
- Fuel filter with water separator
- Fuel filter with water separator heavy-duty
- Switchable fuel filter with water separator
- Switchable fuel filter with water separator heavy-duty
- Seperate fuel cooler
- Fuel cooler integrated into cooling equipment

### Starting/charging system

- 24V starter
- Starter batteries, cables, rack, disconnect switch
- Battery charger
- Redundant starter 2x 15kW

### Mounting system

- Welded base frame
- Resilient engine and generator mounting
- Modular base frame design

### Exhaust system

- Exhaust bellows with connection flange
- Exhaust silencer with 10 dB(A) sound attenuation
- Exhaust silencer with 30 dB(A) sound attenuation
- Exhaust silencer with 40 dB(A) sound attenuation
- Y-connection-pipe

Represents standard features

Represents optional features

## Weights and dimensions

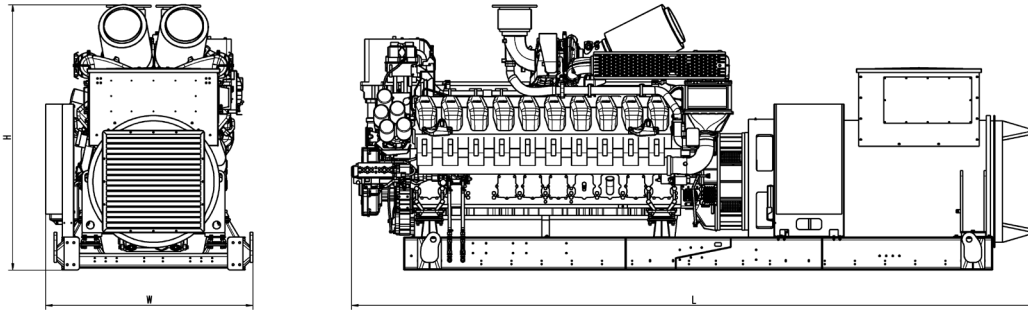

Drawing above for illustration purposes only, based on a standard open power 11 kV engine-generator set. Lengths may vary with other voltages. Do not use for installation design. See website for unit specific template drawings.

System	Dimensions (LxWxH)	Weight (dry/less tank)
Open power unit (OPU)	6339 x 1887 x 2415 mm	19350 kg

Weights and dimensions are based on open power units and are estimates only. Consult the factory for accurate weights and dimensions for your specific engine-generator set.

## Sound data

– Consult your local **mtu** distributor for sound data.

## Emissions data

– Consult your local **mtu** distributor for emissions data.

## Rating definitions and conditions

- Standby ratings apply to installations served by a reliable utility source. The standby rating is applicable to varying loads for the duration of a power outage. A 10% overload capacity is available for one hour in twelve. Ratings are in accordance with ISO 8528-1, ISO-3046-1, BS 5514 and AS 2789.  
Average load factor:  $\leq 85\%$ . Operating hours/year: max. 500.
- Consult your local **mtu** distributor for derating information.